



HEATH & SHERWOOD

tuyère silencer

Ball Valve Type

The original Tuyère Silencer forms an integral part of effective tuyere line management..... your path to increased copper production. Ask for the original design!

Higher copper production with lower maintenance and improved safety. Increased process blowing rate by up to 10%.

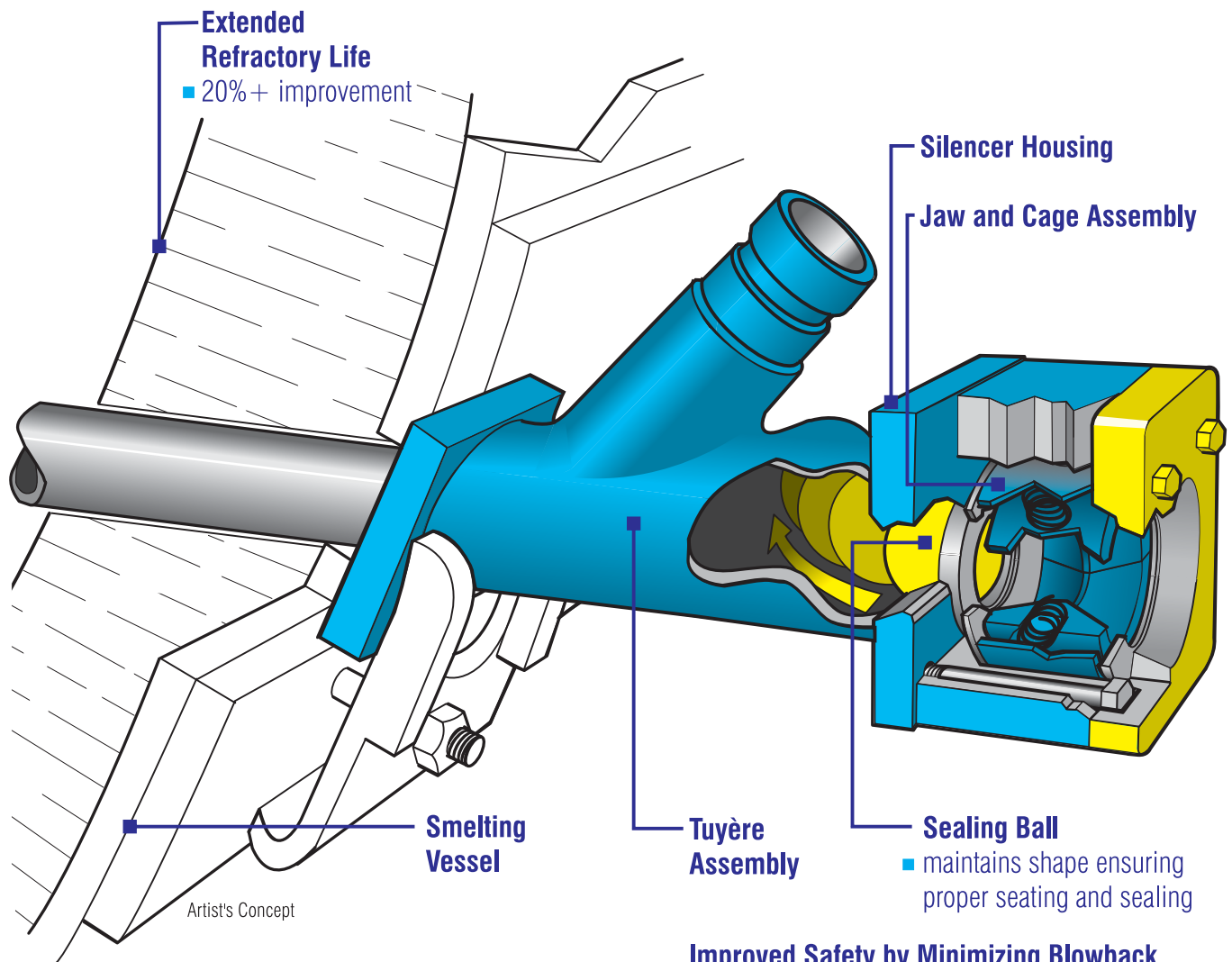

Improved Safety by Minimizing Blowback

- blowback is a safety hazard
- significant reduction in noise levels
- reduction of sparks and flying matte during punching operation

tuyère silencer

Ball Valve Type

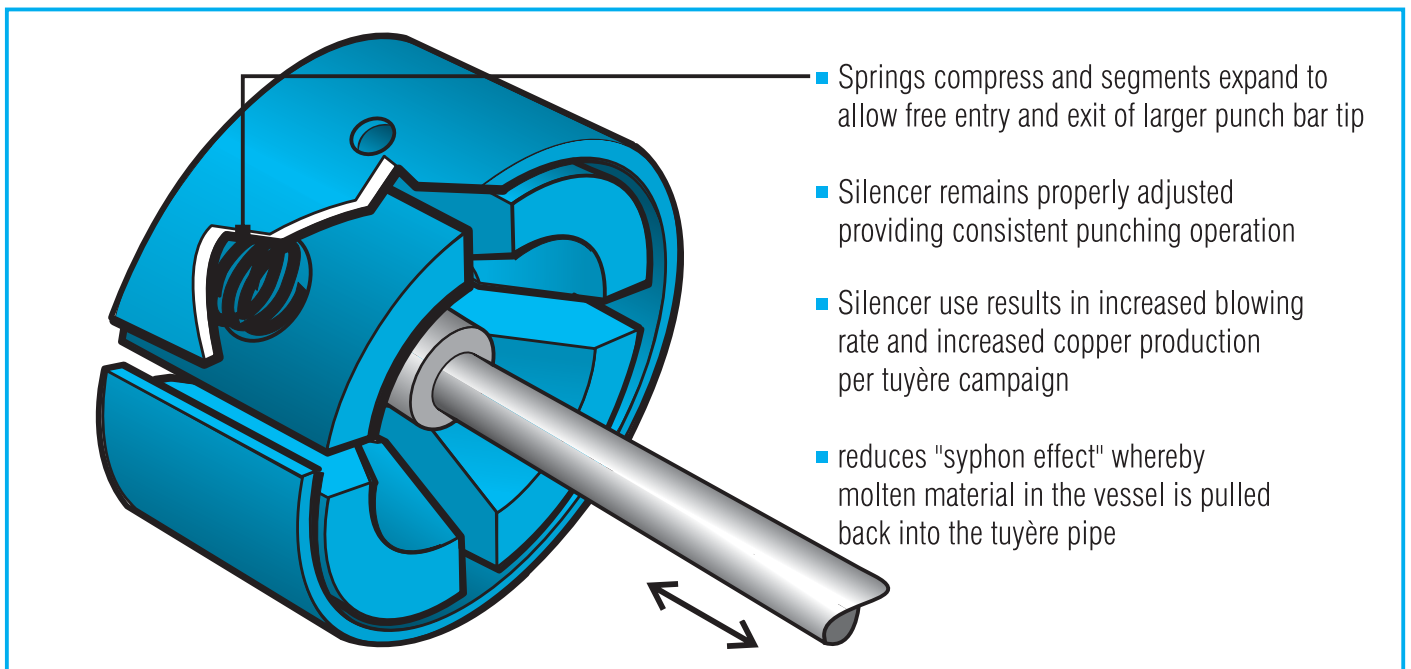
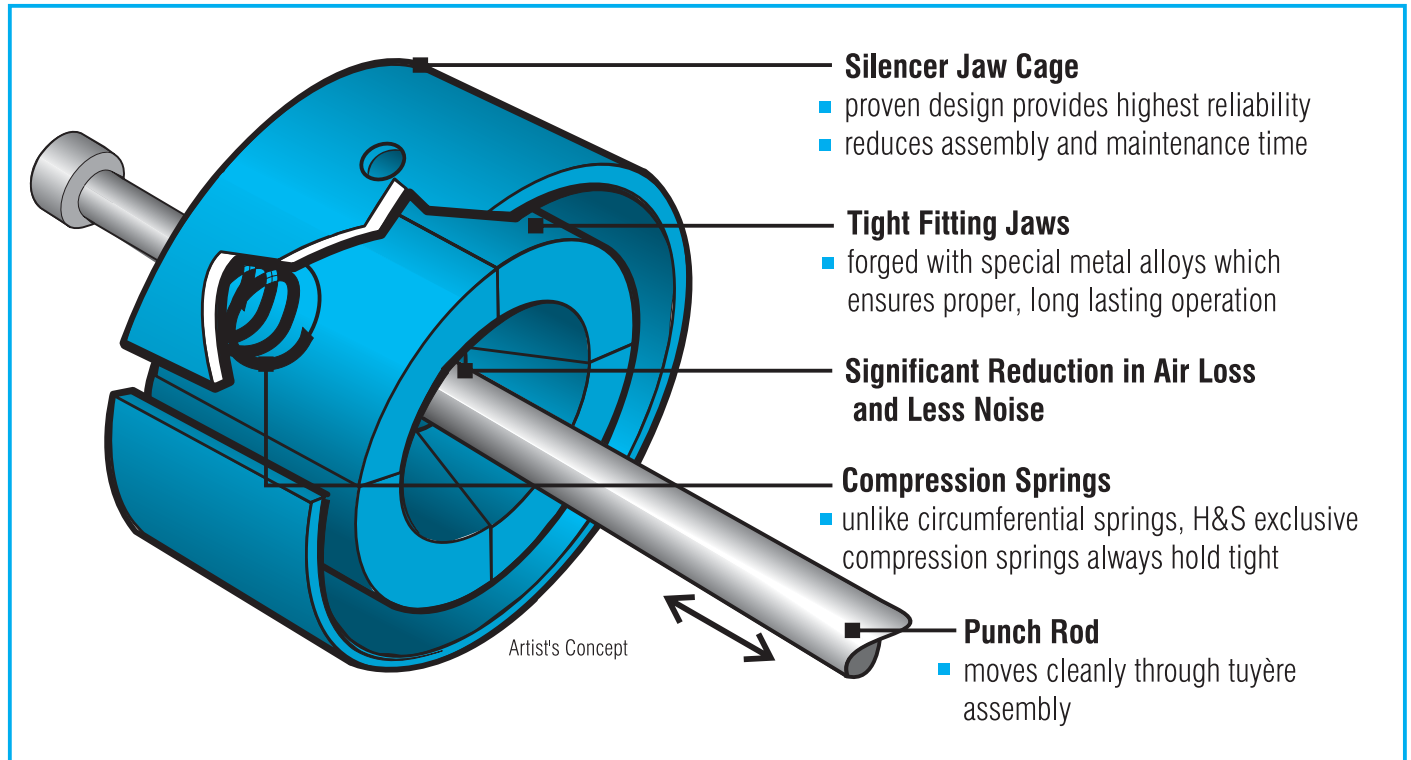

Heath & Sherwood (1964) Limited
Box 340 Kirkland Lake, Ontario
Canada P2N 3J2

Tel: (705) 567-5313
Fax: (705) 567- 8545
Toll Free in North America:
1 888-go sample (467-2675)
email: info@heathandsherwood.com

Subsidiary Offices:
Mississauga, Ontario Canada
Agents World Wide

Visit our website:
www.heathandsherwood.com